

Universal Voltage-type Capacity Tester

—TH01/LY6N/LY6W—

• Sketch :

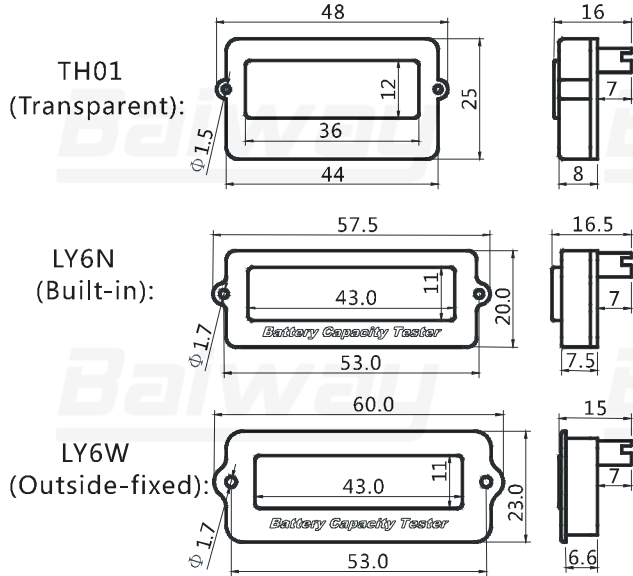

• Application range :

★ TH01/LY6 is designed to test the voltage, current and capacity of battery, and display them with intuitive battery symbol and percentage. Users can know the state of battery in time. It is suitable for instruments, measuring equipments, cleaning machines, balance cars, battery cars and so on.

• Applicable specification :

Lead-acid battery : 12V, 24V, 36V, 48V;

Lithium-ion battery : 3cells ~ 15cells ;

★ The capacity tester is used for 3~15 cells lithium-ion battery (8~63V) and lead-acid battery (12~48V). Lithium iron phosphate battery does not suitable, please select coulometer of our company (TY5 or TF01). Users can select suitable specification by the key on the back (details below).

★ Other specifications (1cell, 2cells and more than 15 cells) should be customized, and the specifications can't be adjusted.

• Connection :

★ The tester provides a connector consists of plug, black line and red line. Connect the black line to the negative, the red line to the positive, the plug to the socket of tester. Then, power on or turn on the switch, it will be work. As shown below:

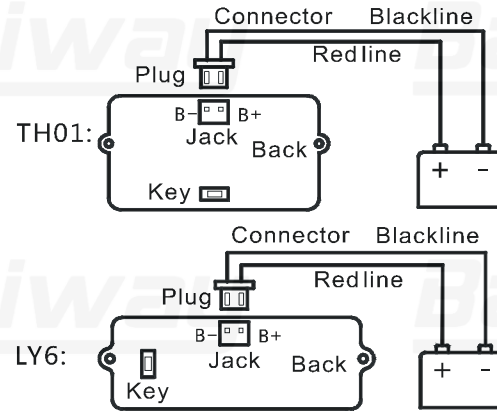

• Install :

★ **TH01/LY6N:** First, open one rectangular orifice and two screw holes on the panel of the equipment. Then install the tester from the back of the panel, and put the prominent LCD in the rectangular orifice. Finally, fix the tester with tapping screws from the front of the panel. As shown below:

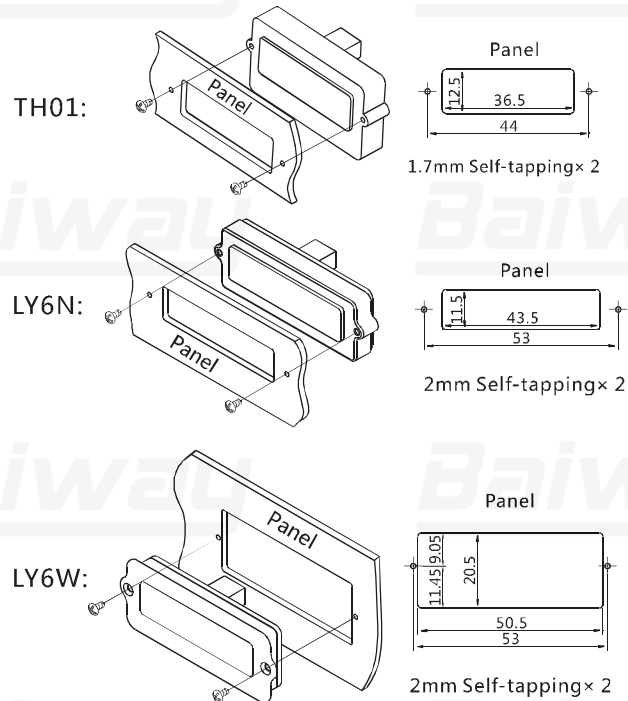

★ **LY6W:** First, open one rectangular orifice and two screw holes on the panel of the equipment. Then install the tester from the front of the panel, and put the shell of tester into the

rectangular orifice. Finally, fix the tester with tapping screws from the front of the panel. As shown above:

• Specification adjustment :

★ Press and hold the down key on the back when turn off, then power on. LCD displays the present specification. Use the down key and up key to adjust specifications, select suitable specification you need, then turn off and power on. The tester will be work normally (correspond code as below form).

| Lithium-ion | Code |
|-------------|------|
| 3 cells | 3 C |
| 4 cells | 4 C |
| 5 cells | 5 C |
| 6 cells | 6 C |
| 7 cells | 7 C |
| 8 cells | 8 C |
| 9 cells | 9 C |
| 10 cells | 10 C |
| 11 cells | 11 C |
| 12 cells | 12 C |
| 13 cells | 13 C |
| 14 cells | 14 C |
| 15 cells | 15 C |

| Lead-acid | Code |
|-----------|------|
| 12V | 1 P |
| 24V | 2 P |
| 36V | 3 P |
| 48V | 4 P |

• Technical parameter :

Operating current : <5.0mA
 Max operating voltage : 63V
 Temperature range : 0°C~40°C
 Weight of TH01 : 15g
 Weight of LY6 : 13g

• Accessory :

- ★ One connector with two lines, 20mm in length. If it is short, please lengthen it by yourself.
- ★ **TH01:** M1.7×5mm self-tapping screw×4 (round head×2, countersunk head×2).
- ★ **LY6N/LY6W:** M2.0×6mm self-tapping screw×4 (round head×2, countersunk head×2).

• Attention and warranty :

- ★ The tester cannot be exposed in the sun for a long time. When using or storing, please keep the temperature higher than -20°C and lower than 60°C, otherwise it will shorten the life of LCD.
- ★ Within one year, any fault caused by non-artificial reason we should maintain it freely.

Our products will keep upgrading, if the product you bought is different with this instruction, please take the material object or website as the standard.